

EXECUTIVE SUMMARY

This Inflow Flood Control Plan (Report) is prepared in accordance with the requirements of the United States Environmental Protection Agency (USEPA) published Final Rule for Hazardous and Solid Waste Management System - Disposal of Coal Combustion Residual from Electric Utilities (40 CFR Parts 257 and 261, also known as the CCR Rule) published on April 17, 2015 and effective October 19, 2015.

This Report assesses the hydrologic and hydraulic capacity requirements for each CCR unit at Nelson Dewey Generating Station in Cassville, Wisconsin in accordance with §257.82 of the CCR Rule. For purposes of this Report, a CCR unit is defined as any existing CCR surface impoundment. Primarily, the Report documents how the inflow design flood control system has been designed and constructed to meet the CCR Rule section §257.82.



Table of Contents

1	Introduction	1
1.1	CCR Rule Applicability	1
1.2	Hydrologic and Hydraulic Capacity Applicability	1
2	FACILITY DESCRIPTION	2
2.1	NED Slag Pond	3
3	HYDROLOGIC AND HYDRAULIC CAPACITY- §257.82(a)	5
3.1	Hazard Classification and Design Storm	5
3.2	Hydrologic and Hydraulic Capacity Methods	5
3.3	Hydrologic and Hydraulic Capacity Input and Assumptions	6
4	Inflow Design Flood Control System Plan	7
5	QUALIFIED PROFESSIONAL ENGINEER CERTIFICATION	8

Figures

Figure 1: Inflow Flood Control Site Plan

Figure 2: Storm Water Routing

Appendices

Appendix A: NOAA Storm Frequency Tabulation

Appendix B: Wet Well and Overflow Weir Information and Picture

Appendix C: NED Slag Pond Topography and Bathymetry

Appendix D: Inflow Flood Control Analysis



1 Introduction

The owner or operator of the Coal Combustion Residual (CCR) unit must conduct an initial and periodic inflow design flood control system plan to determine if each CCR unit adequately manages flow into and from each CCR unit during and following the peak discharge of the inflow design flood. The inflow design flood is selected based on the hazard potential classification (§257.73(a)(2)) for each CCR unit.

This Report is prepared in accordance with the requirements of §257.82 of the CCR Rule.

1.1 CCR Rule Applicability

The CCR Rule requires an initial and periodic inflow design flood control system plan certified by a qualified professional engineer (PE) for all existing CCR surface impoundments. This report is the initial inflow design flood control system plan.

1.2 Hydrologic and Hydraulic Capacity Applicability

The Nelson Dewey Generating Station (NED) in Cassville, Wisconsin (Figure 1) has one existing CCR surface impoundment, identified as follows:

- NED Slag Pond

Wisconsin Power and Light Company also has one inactive CCR surface impoundment, the NED WPDES Pond. The NED WPDES Pond will be handled under a separate transmittal in accordance with the CCR Rule, if needed, and is not discussed further herein.



2 FACILITY DESCRIPTION

NED is located north of the Village of Cassville, Wisconsin on the eastern shore of the Mississippi River in Grant County, at 11999 County Highway VV, Cassville, Wisconsin (Figure 1). Located north of the generating plant is Stonefield Village (a state historical landmark) and Nelson Dewey State Park.

NED was a fossil-fueled electric generating station consisting of two steam electric generating units that were retired in December 2015. Sub-bituminous coal was the primary fuel for producing steam. The burning of coal produces a by-product of CCR. The CCR at NED was categorized into two types, slag and fly ash. The fly ash was collected by the electrostatic precipitators and pneumatically conveyed to the on-site fly ash storage silo that is equipped with a baghouse for dust control. The fly ash was then transported off-site for beneficial reuse. The slag was sluiced to a surface impoundment identified as the NED Slag Pond (Figure 2). The NED Slag Pond is located northwest of the generating plant and is presently the only existing CCR surface impoundment at NED.

General Facility Information:

Date of Initial Facility Operations:	1959
WPDES Permit Number:	WI-0002381-07-0
Latitude / Longitude:	42° 43' 30.792" N -91° 0' 40.032" W
Unit Nameplate Ratings:	Unit 1 (1959): 100 MW Unit 2 (1961): 100 MW



2.1 NED Slag Pond

The NED Slag Pond is located northwest of the generating plant and south of the on-site closed ash landfill, Figure 2. The NED Slag Pond receives storm water runoff from part of the on-site closed ash landfill, and the slag handling area. The NED Slag Pond was the primary receiver of process flows from the generating plant prior to December 31, 2015 when the facility's generating units retired. Wastewater was also periodically pumped from the NED WPDES Pond to the NED Slag Pond. Process flows, prior to the facility ceasing operations, included sluiced CCR (slag) from the slag tanks located inside the generating plant, and flows associated with the seal well sump pumps. Flows from the seal well sump pumps included soot blowers, air compressors, boiler blowdown, Unit 1 and Unit 2 floor sumps, oil and hydrogen coolers and demineralization/reverse osmosis multi-media units.

Prior to the facility ceasing operations, the sluiced slag was discharged into the east end of the NED Slag Pond where the majority of CCR was recovered. A dozer was used to push the CCR towards an excavator for dredging. Prior to October 19, 2015, the dredged CCR was stockpiled adjacent to the NED Slag Pond for dewatering. Once dewatered, the CCR was transported off-site for beneficial use. CCR has not been added to any stockpiles outside of the NED Slag Pond on or after October 19, 2015, the effective date of the CCR Rule.

The water used to sluice the CCR from the generating plant to the NED Slag Pond flowed from the east end to the west end of the NED Slag Pond. The southwest corner of the NED Slag Pond consists of the facility's Wisconsin Pollution Discharge Elimination System (WPDES) Outfall 002. The concrete outfall structure includes a rectangular weir restriction that discharges into a 30-inch diameter reinforced concrete pipe (RCP). The water flows through the WPDES Outfall 002, under the embankment on the west side of the NED Slag Pond, and discharges into a riprap lined swale that flows to the southwest into the Mississippi River.



The surface area of the NED Slag Pond is approximately 4.8 acres and has an embankment height of approximately 15 feet from the crest to the toe of the downstream slope. The interior storage depth of the NED Slag Pond is approximately 10 feet. The total volume of impounded CCR and water within the NED Slag Pond is approximately 75,000 cubic yards.



3 HYDROLOGIC AND HYDRAULIC CAPACITY- §257.82(a)

This Report provides hydrologic and hydraulic capacity information for inflow design flood control systems which is intended to:

1. Adequately manage flow into each CCR unit during and following the peak discharge inflow of the specified design flood,
2. Adequately manage flow from each CCR unit during and following the peak discharge inflow of the specified design flood; and,
3. Handle discharge from the CCR unit in accordance with National Pollutant Discharge Elimination System (NPDES) regulations §257.3-3.

3.1 Hazard Classification and Design Storm

The NED Slag Pond is classified as a low hazard potential because a release from the CCR surface impoundment would principally be limited to the facility property with low economic losses and environmental damages.

The design storm for the NED Slag Pond is the 100 year return event SCS Type II 24 hour storm as defined in 40 CFR 257.82 (3) (ii). The total rainfall for the event selected from the National Oceanographic and Atmospheric Administration's probabilistic map for the NED site coordinates is 7.5 inches for the 100 year event, Appendix A.

3.2 Hydrologic and Hydraulic Capacity Methods

The impoundment discharges through a 2 foot wide overflow weir set at elevation 615.3 feet above mean sea level in a concrete wet well in the west corner of the impoundment. The overflowing water discharges through a flush face 30-inch diameter RCP pipe at invert elevation 615.0 feet. The water flows by pipe through the NED Slag Pond embankment and into a swale, which discharges to the Mississippi River. The overflow weir is 2 foot wide and 1.1 foot high and was used to monitor flow from the NED Slag Pond up to a stage of 1.1 foot above the bottom of the weir. During a large rainfall event the flow will exceed the weir capacity and overflow the weir which is installed in the six foot wide wet well, Appendix B. Therefore, the NED Slag Pond outlet is modeled as a combined overflow weir action and entrance controlled pipe culvert outlet, Appendix B.



The 100 year SCS Type II Storm routing was completed using the program Hydraflow by Intelisolve¹. Hydraflow uses the unit hydrograph method to generate a Type II distributed rainfall for the contributing drainage area of 30 acres, Figure 2. Hydraflow routes the unit hydrograph through the outlet structure of the NED Slag pond storing water within the impoundment in accordance with the input reservoir capacity, Appendix C. The proportion of runoff to rainfall for the drainage is input based on the infiltration characteristics of the area.

3.3 Hydrologic and Hydraulic Capacity Input and Assumptions

This section identifies the input and assumptions for the hydrologic and hydraulic capacity calculations. The input for the 30 acre drainage area, Figure 2, is assigned an average runoff Curve Number (CN) of 83, a slope of 4% and a hydraulic length of 690 feet. The slope and hydraulic length for the closed landfill control the arrival of the peak water from rainfall due to the percentage of acreage from the landfill area.

There is no operating water flow from the closed facility into the NED Slag Pond with the exception of a *de minimis* flow of sump water from the basement floor sumps. Normal water elevation in the impoundment is related to the water elevation in the adjacent Mississippi River. The normal pool for the river at Cassville is approximately 603 feet flat pool and the flood stage is 614.5 feet, United States Army Corps of Engineers. At flood stage, the outlet of the NED Slag Pond will not be submerged and the NED Slag Pond water elevation is assumed to be at the bottom of the outlet weir 615.3 feet at the beginning of the storm routing.

¹ Intelisolve, Pond Routing Software Hydraflow, 2002
Wisconsin Power and Light Company – Nelson Dewey Generating Station
Inflow Design Flood Control System Plan
September 20, 2016



4 Inflow Design Flood Control System Plan

The 30 acres of storm water flow into the NED Slag Pond will discharge from the outlet at a maximum flow of 22.2 cubic feet per second during the storm. The NED Slag Pond will store 7.9 acre feet of water during the event and the maximum water elevation will reach 617.1 feet. The minimum crest elevation of the embankment is elevation 620 on the southeast corner with a resultant freeboard of 2.9 feet at the peak of the storm flow.

The results of the storm routing through the NED Slag Pond using Hydraflow are presented in Appendix D.



5 QUALIFIED PROFESSIONAL ENGINEER CERTIFICATION

To meet the requirements of 40 CFR 257.82(c)(5), I Mark W. Loerop hereby certify that I am a licensed professional engineer in the State of Wisconsin; and that, to the best of my knowledge, all information contained in this document is correct and the document was prepared in compliance with all applicable requirements in 40 CFR 257.82.



By: 

Name: MARK LOEROP

Date: SEP 20, 2016



FIGURES

Alliant Energy
Wisconsin Power and Light Company
Nelson Dewey Generating Station
Cassville, Wisconsin

Inflow Design Flood Control System Plan



Historical Topo Map

2013

Historical Aerial Photo 5/30/2015

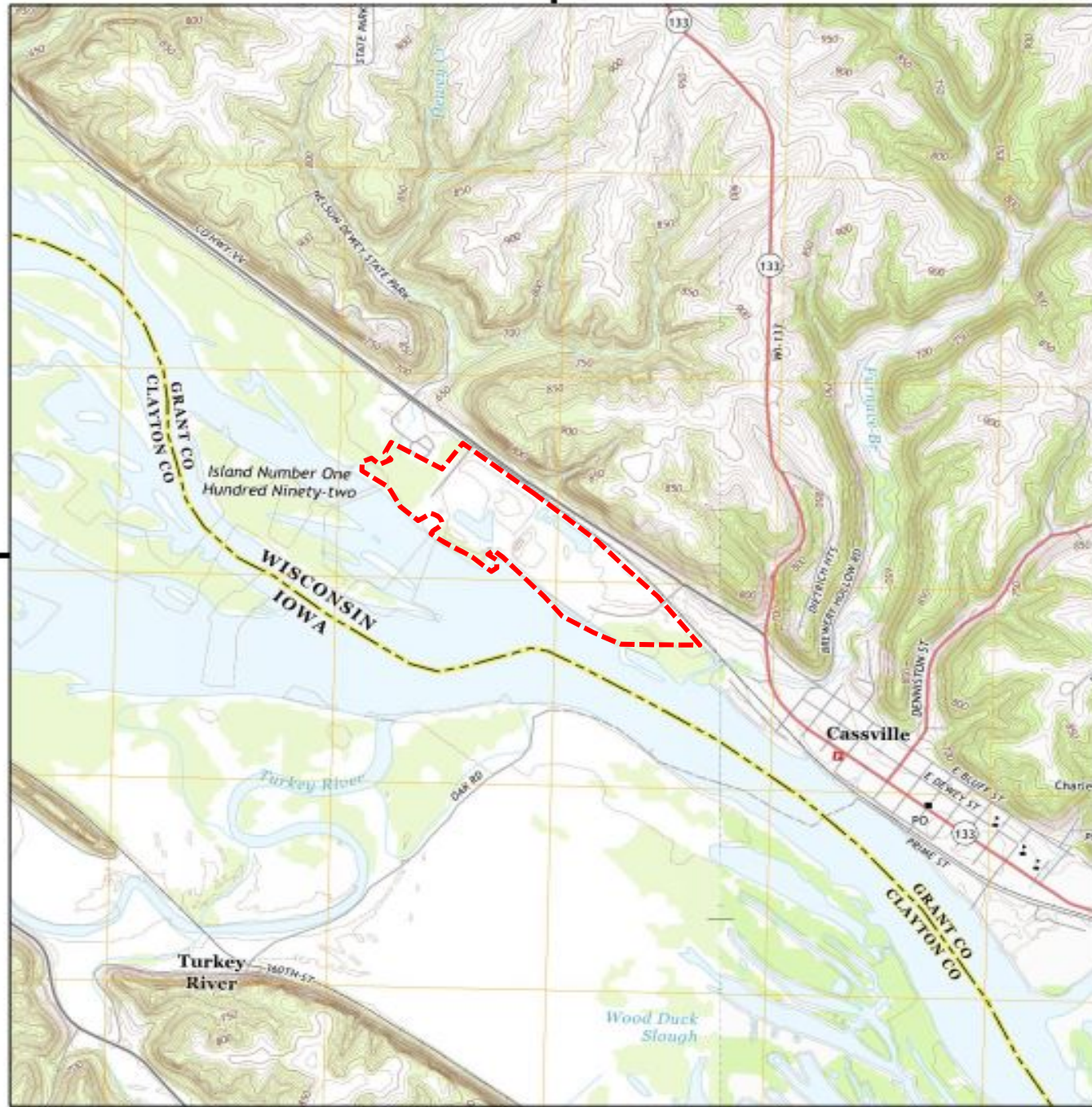

This report includes information from the following map sheet(s).

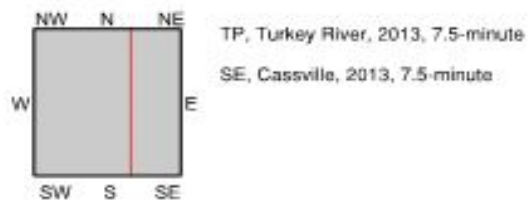

SITE NAME: Nelson Dewey Generating Station
ADDRESS: 11999 County Highway VV
Cassville, WI 53806
CLIENT: Environmental Site Assessors



----- Approximate Property Boundary



HARD HAT SERVICESTM
Engineering, Construction and Management Solutions

Site Location
Nelson Dewey Generating Station
Wisconsin Power and Light Company

Drawing
Figure 1
Date
7/13/2016

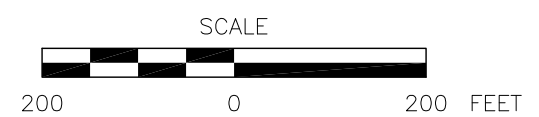
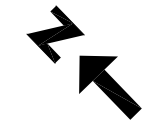
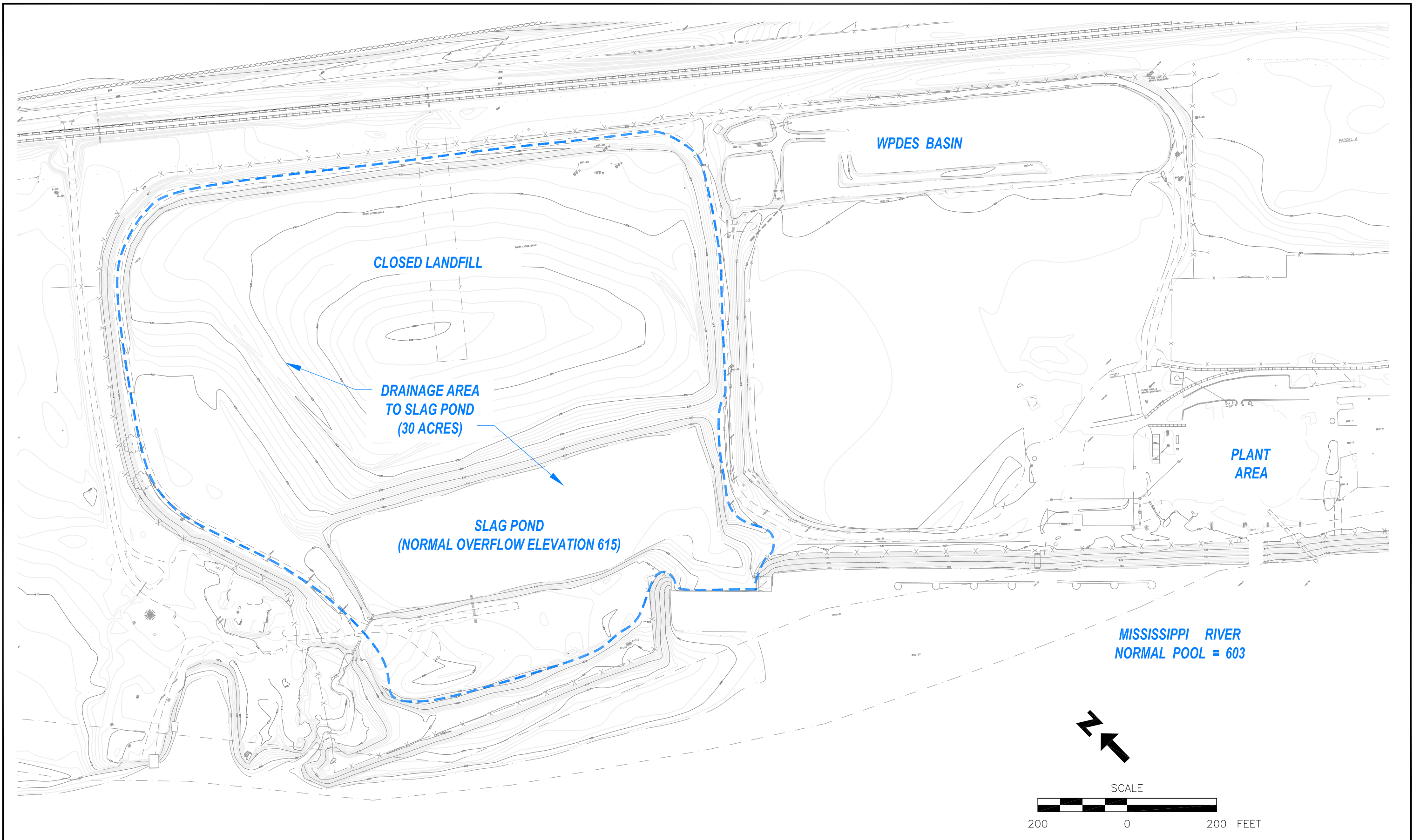

NOTICE
THIS DRAWING IS THE PROPERTY
OF HARD HAT SERVICES AND IS
NOT TO BE REPRODUCED,
CHANGED, OR COPIED IN ANY FORM
OR MANNER WITHOUT PRIOR
WRITTEN PERMISSION. ALL RIGHTS
RESERVED.

REV	DATE	BY	DESCRIPTION



SCALE: AS SHOWN
DATE: 8-22-16
DRAWN BY: JFD
CHKD BY: TJH
APRVD BY: MWL

CLIENT / LOCATION
WISCONSIN POWER AND LIGHT
NELSON DEWEY GENERATING STATION
CASSVILLE, WISCONSIN

DRAWING DESCRIPTION
INFLOW DESIGN FLOOD CONTROL PLAN
SITE PLAN

JOB 154.018.012.007
SHT. 2
DWG. 154018012-IFC

APPENDIX A – NOAA Storm Frequency Tabulation

Alliant Energy
Wisconsin Power and Light Company
Nelson Dewey Generating Station
Cassville, Wisconsin

Inflow Design Flood Control System Plan





NOAA Atlas 14, Volume 8, Version 2
Location name: Cassville, Wisconsin, US*
Latitude: 42.7246°, Longitude: -91.0095°
Elevation: 624 ft*
 * source: Google Maps



POINT PRECIPITATION FREQUENCY ESTIMATES

Sanja Perica, Deborah Martin, Sandra Pavlovic, Ishani Roy, Michael St. Laurent, Carl Trypaluk, Dale Unruh, Michael Yekta, Geoffery Bonnin

NOAA, National Weather Service, Silver Spring, Maryland

[PF tabular](#) | [PF graphical](#) | [Maps & aerials](#)

PF tabular

PDS-based point precipitation frequency estimates with 90% confidence intervals (in inches)¹										
Duration	Average recurrence interval (years)									
	1	2	5	10	25	50	100	200	500	1000
5-min	0.373 (0.299-0.470)	0.439 (0.351-0.554)	0.551 (0.439-0.695)	0.647 (0.512-0.819)	0.784 (0.602-1.02)	0.893 (0.670-1.18)	1.01 (0.730-1.35)	1.12 (0.782-1.54)	1.29 (0.861-1.80)	1.41 (0.921-2.00)
10-min	0.547 (0.437-0.688)	0.643 (0.514-0.811)	0.806 (0.642-1.02)	0.947 (0.750-1.20)	1.15 (0.882-1.50)	1.31 (0.981-1.72)	1.47 (1.07-1.98)	1.65 (1.15-2.26)	1.88 (1.26-2.64)	2.07 (1.35-2.93)
15-min	0.667 (0.533-0.839)	0.784 (0.627-0.989)	0.984 (0.783-1.24)	1.16 (0.915-1.46)	1.40 (1.08-1.83)	1.60 (1.20-2.10)	1.80 (1.30-2.41)	2.01 (1.40-2.75)	2.30 (1.54-3.22)	2.52 (1.64-3.57)
30-min	0.917 (0.734-1.16)	1.09 (0.868-1.37)	1.37 (1.09-1.73)	1.61 (1.28-2.04)	1.96 (1.50-2.56)	2.24 (1.68-2.94)	2.52 (1.83-3.38)	2.82 (1.96-3.86)	3.22 (2.16-4.51)	3.54 (2.31-5.01)
60-min	1.18 (0.947-1.49)	1.39 (1.11-1.76)	1.77 (1.41-2.23)	2.10 (1.66-2.66)	2.59 (2.00-3.41)	3.00 (2.26-3.98)	3.44 (2.50-4.64)	3.90 (2.73-5.38)	4.56 (3.06-6.42)	5.09 (3.32-7.20)
2-hr	1.45 (1.17-1.81)	1.70 (1.38-2.12)	2.16 (1.74-2.70)	2.58 (2.07-3.24)	3.23 (2.53-4.22)	3.77 (2.87-4.97)	4.36 (3.20-5.85)	4.99 (3.52-6.85)	5.90 (4.00-8.26)	6.64 (4.36-9.34)
3-hr	1.63 (1.32-2.01)	1.89 (1.54-2.35)	2.40 (1.94-2.98)	2.88 (2.32-3.59)	3.64 (2.88-4.77)	4.29 (3.30-5.65)	5.01 (3.71-6.72)	5.81 (4.12-7.95)	6.96 (4.74-9.73)	7.90 (5.21-11.1)
6-hr	1.95 (1.61-2.39)	2.24 (1.84-2.74)	2.80 (2.29-3.44)	3.36 (2.73-4.14)	4.27 (3.43-5.58)	5.09 (3.96-6.67)	6.00 (4.50-8.01)	7.02 (5.04-9.58)	8.52 (5.87-11.9)	9.77 (6.50-13.6)
12-hr	2.30 (1.92-2.79)	2.59 (2.15-3.15)	3.19 (2.64-3.87)	3.79 (3.12-4.63)	4.80 (3.90-6.22)	5.70 (4.48-7.42)	6.72 (5.09-8.92)	7.88 (5.71-10.7)	9.59 (6.66-13.3)	11.0 (7.38-15.2)
24-hr	2.64 (2.21-3.16)	2.97 (2.49-3.56)	3.64 (3.04-4.38)	4.31 (3.58-5.20)	5.40 (4.42-6.91)	6.38 (5.06-8.20)	7.47 (5.70-9.80)	8.69 (6.35-11.7)	10.5 (7.35-14.4)	12.0 (8.11-16.5)
2-day	2.96 (2.51-3.50)	3.37 (2.86-4.00)	4.16 (3.52-4.95)	4.93 (4.14-5.88)	6.14 (5.06-7.73)	7.19 (5.75-9.12)	8.35 (6.43-10.8)	9.64 (7.09-12.8)	11.5 (8.12-15.7)	13.1 (8.90-17.8)
3-day	3.23	3.65	4.44	5.21	6.44	7.51	8.71	10.0	12.0	13.6

	(2.77-3.81)	(3.11-4.30)	(3.78-5.24)	(4.41-6.18)	(5.34-8.06)	(6.04-9.48)	(6.74-11.2)	(7.43-13.3)	(8.49-16.2)	(9.29-18.5)
4-day	3.48 (2.99-4.08)	3.89 (3.34-4.57)	4.68 (4.01-5.51)	5.46 (4.64-6.44)	6.69 (5.57-8.33)	7.77 (6.27-9.76)	8.97 (6.97-11.5)	10.3 (7.65-13.6)	12.3 (8.71-16.5)	13.9 (9.52-18.8)
7-day	4.11 (3.57-4.78)	4.60 (3.98-5.34)	5.48 (4.73-6.39)	6.30 (5.41-7.38)	7.56 (6.32-9.27)	8.64 (7.01-10.7)	9.81 (7.66-12.4)	11.1 (8.27-14.4)	12.9 (9.22-17.3)	14.4 (9.95-19.4)
10-day	4.69 (4.09-5.41)	5.25 (4.57-6.06)	6.23 (5.41-7.21)	7.10 (6.13-8.27)	8.41 (7.04-10.2)	9.49 (7.73-11.6)	10.6 (8.34-13.4)	11.9 (8.88-15.3)	13.6 (9.75-18.1)	15.0 (10.4-20.1)
20-day	6.41 (5.66-7.32)	7.13 (6.29-8.14)	8.34 (7.33-9.55)	9.38 (8.18-10.8)	10.8 (9.14-12.9)	12.0 (9.86-14.5)	13.2 (10.4-16.4)	14.5 (10.9-18.5)	16.2 (11.7-21.2)	17.5 (12.2-23.4)
30-day	7.91 (7.03-8.96)	8.78 (7.79-9.95)	10.2 (9.03-11.6)	11.4 (10.0-13.0)	13.1 (11.0-15.4)	14.3 (11.8-17.2)	15.6 (12.4-19.2)	17.0 (12.8-21.5)	18.7 (13.6-24.4)	20.1 (14.1-26.7)
45-day	9.85 (8.81-11.1)	11.0 (9.79-12.3)	12.7 (11.3-14.4)	14.2 (12.5-16.1)	16.1 (13.7-18.8)	17.6 (14.6-20.8)	19.0 (15.1-23.2)	20.4 (15.5-25.7)	22.2 (16.2-28.8)	23.6 (16.7-31.2)
60-day	11.5 (10.4-12.9)	12.9 (11.6-14.4)	15.0 (13.4-16.8)	16.7 (14.8-18.8)	18.9 (16.1-21.9)	20.5 (17.0-24.2)	22.1 (17.6-26.7)	23.6 (17.9-29.4)	25.4 (18.5-32.8)	26.8 (19.0-35.3)

¹ Precipitation frequency (PF) estimates in this table are based on frequency analysis of partial duration series (PDS). Numbers in parenthesis are PF estimates at lower and upper bounds of the 90% confidence interval. The probability that precipitation frequency estimates (for a given duration and average recurrence interval) will be greater than the upper bound (or less than the lower bound) is 5%. Estimates at upper bounds are not checked against probable maximum precipitation (PMP) estimates and may be higher than currently valid PMP values. Please refer to NOAA Atlas 14 document for more information.

[Back to Top](#)

PF graphical

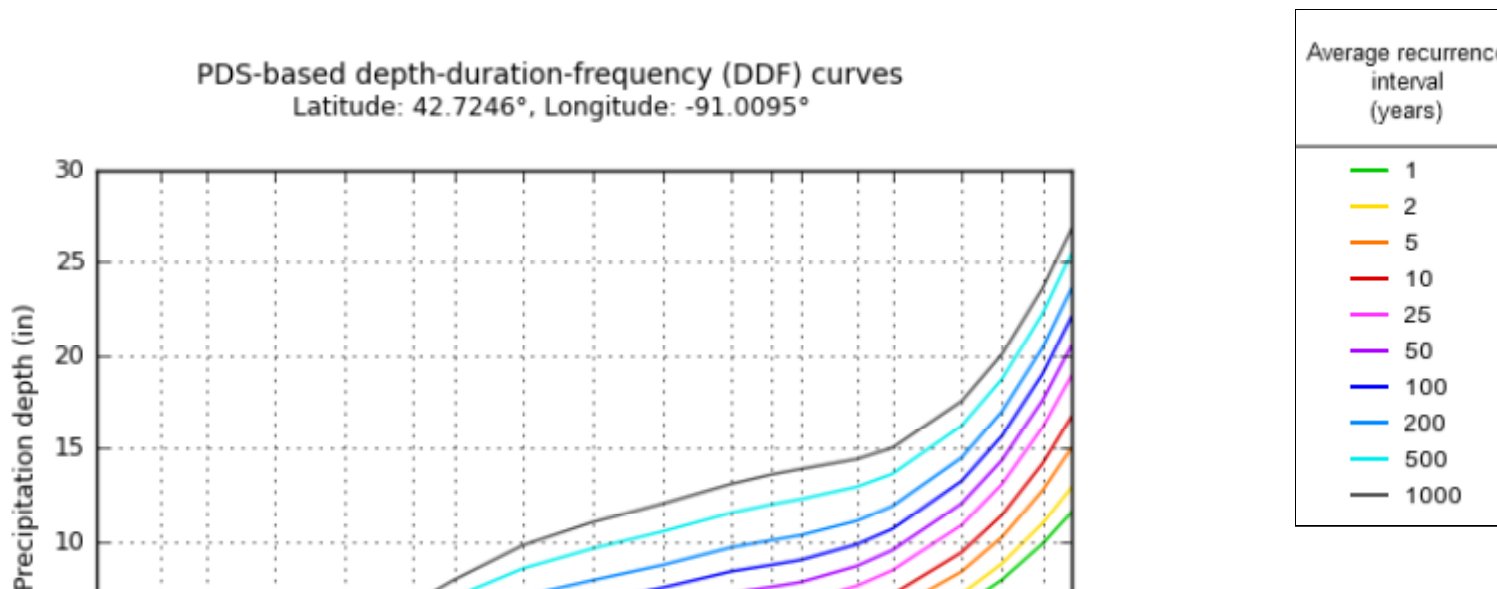

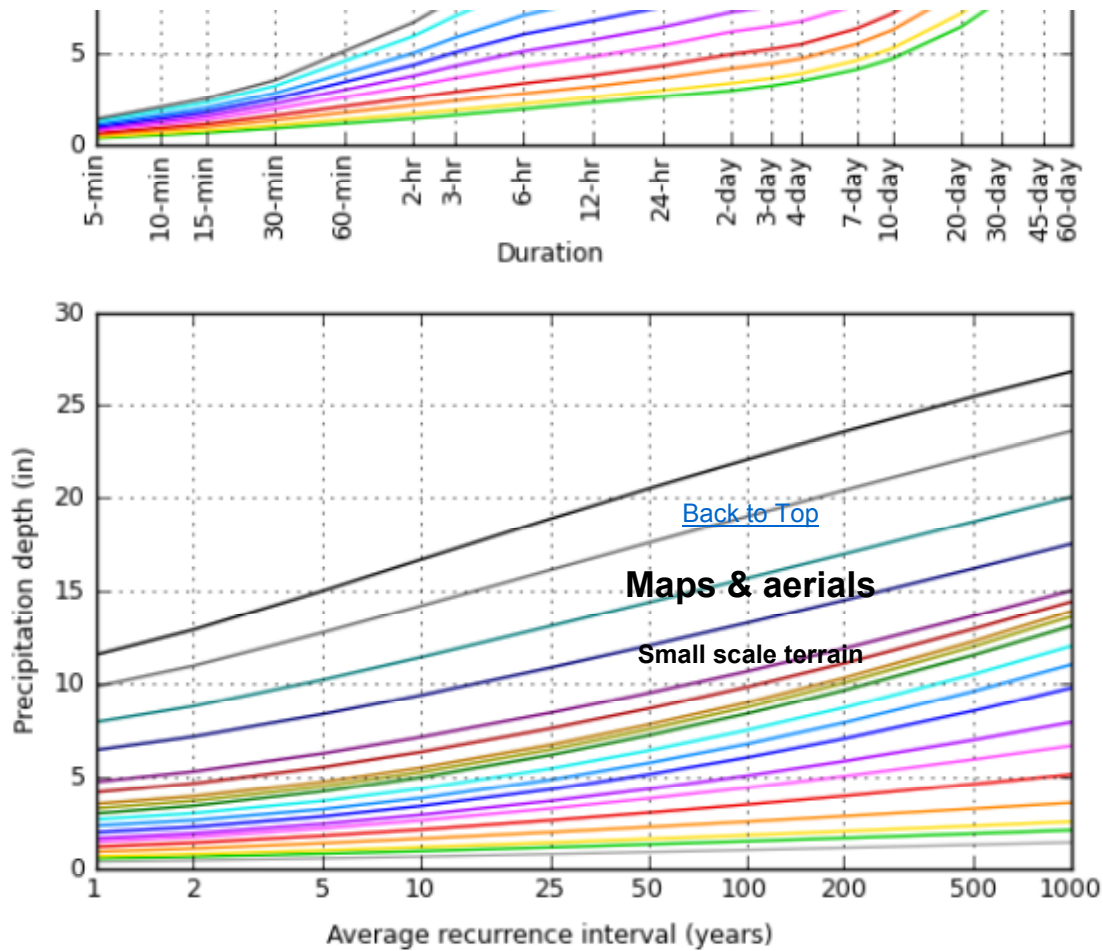

NOAA Atlas 14, Volume 8, Version 2

Created (GMT): Fri Aug 5 21:02:55 2016





Large scale map





[Back to Top](#)

[US Department of Commerce](#)
[National Oceanic and Atmospheric Administration](#)
[National Weather Service](#)
[National Water Center](#)
1325 East West Highway
Silver Spring, MD 20910
Questions?: HDSC.Questions@noaa.gov

[Disclaimer](#)

**APPENDIX B – Wet Well and Overflow
Weir Information and Picture**

Alliant Energy
Wisconsin Power and Light Company
Nelson Dewey Generating Station
Cassville, Wisconsin

Inflow Design Flood Control System Plan



NELSON DEWEY OUTLET STRUCTURE

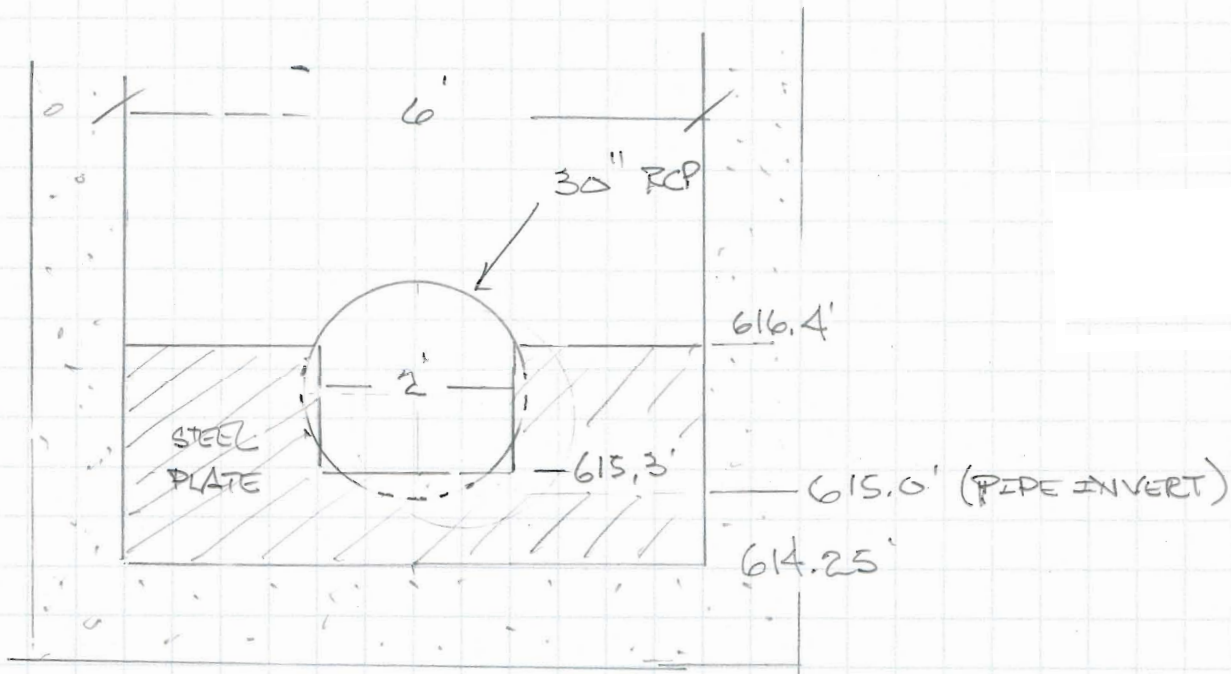

FROM WARZYN ... 2 OF 22 ... 3-21-78

&

PICTURE OF MET WELL



20
19
18
17
16
15
14
13
12
11
10

20
9
8
7
6
5
4
3
2
1

1
2
3
4
5
6
7
8
9
10

CASSville - Slag Pond Outlet Discharge Curve

- 2.5 FT = Pipe Diameter Steel
- 0.625 FT = Hydraulic Radius
- 3.1933 k in Q outlet control equation
- 615 FT = Pipe Inlet Invert Elevation
- 50 FT = Length
- 0.025 = n for RCP
- 0.6 = Co for Inlet Control
- 614.25 FT = Tail Water Elevation
- 2 FT = Weir Width (to 616.4')
- 3.3 = Weir Coefficient

OUTLET CONTROL / BARROW CONTROL

Q CFS	Elevation	Head Ft
22.579	615.3	1.0
24.636	615.5	1.3
29.15	616.0	1.8
33.053	616.5	2.3
36.541	617.0	2.8
39.725	617.5	3.3
42.671	618.0	3.8
45.427	618.5	4.3
48.025	619.0	4.8
50.489	619.5	5.3
52.839	620.0	5.8
55.088	620.5	6.3
57.249	621.0	6.8
59.332	621.5	7.3
61.344	622.0	7.8
63.292	622.5	8.3
65.181	623.0	8.8
67.018	623.5	9.3
68.805	624.0	9.8

INLET CONTROL

Q CFS	Elevation	Head (to pipe middle) Ft
0	616.3	0
11.813	616.5	0.25
20.461	617.0	0.75
26.415	617.5	1.25
31.254	618.0	1.75
35.439	618.5	2.25
39.179	619.0	2.75
42.592	619.5	3.25
45.751	620.0	3.75
48.706	620.5	4.25
51.491	621.0	4.75
54.134	621.5	5.25
56.653	622.0	5.75
59.065	622.5	6.25
61.382	623.0	6.75
63.615	623.5	7.25
65.772	624.0	7.75
67.86	624.5	8.25
69.886	625.0	8.75

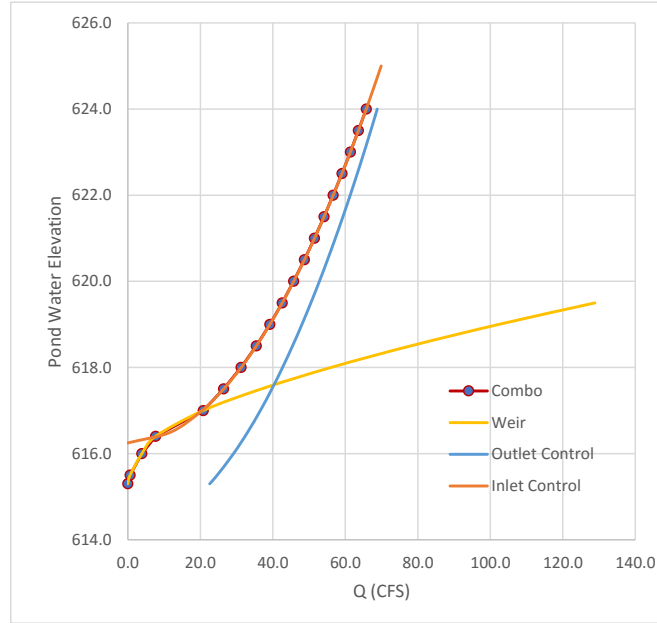

Weir Equation

$$Q = C_w * L * H^{1.5}$$

H Ft	Q CFS	2 foot width + 4' Width	
615.3	0.0	0.0	
615.5	0.6	0.6	
616.0	3.9	3.9	
616.4	7.6	7.6	0
617.0	20.8	14.6	6.1
617.5	36.8	21.5	15.2
618.0	56.0	29.3	26.7
618.5	78.0	37.8	40.2
619.0	102.3	47.0	55.3
619.5	128.9	56.8	72.0

Combo Discharge Curve

Q	Elevation	Control Type
615.3	0.0	Weir Control
615.5	0.6	
616.0	3.9	
616.4	7.6	
617.0	20.8	Inlet Control
617.5	26.4	
618.0	31.3	
618.5	35.4	
619.0	39.2	
619.5	42.6	
620.0	45.8	
620.5	48.7	
621.0	51.5	
621.5	54.1	
622.0	56.7	
622.5	59.1	
623.0	61.4	
623.5	63.6	
624.0	65.8	

APPENDIX C – NED Slag Pond Topography and

Alliant Energy
Wisconsin Power and Light Company
Nelson Dewey Generating Station
Cassville, Wisconsin

Inflow Design Flood Control System Plan



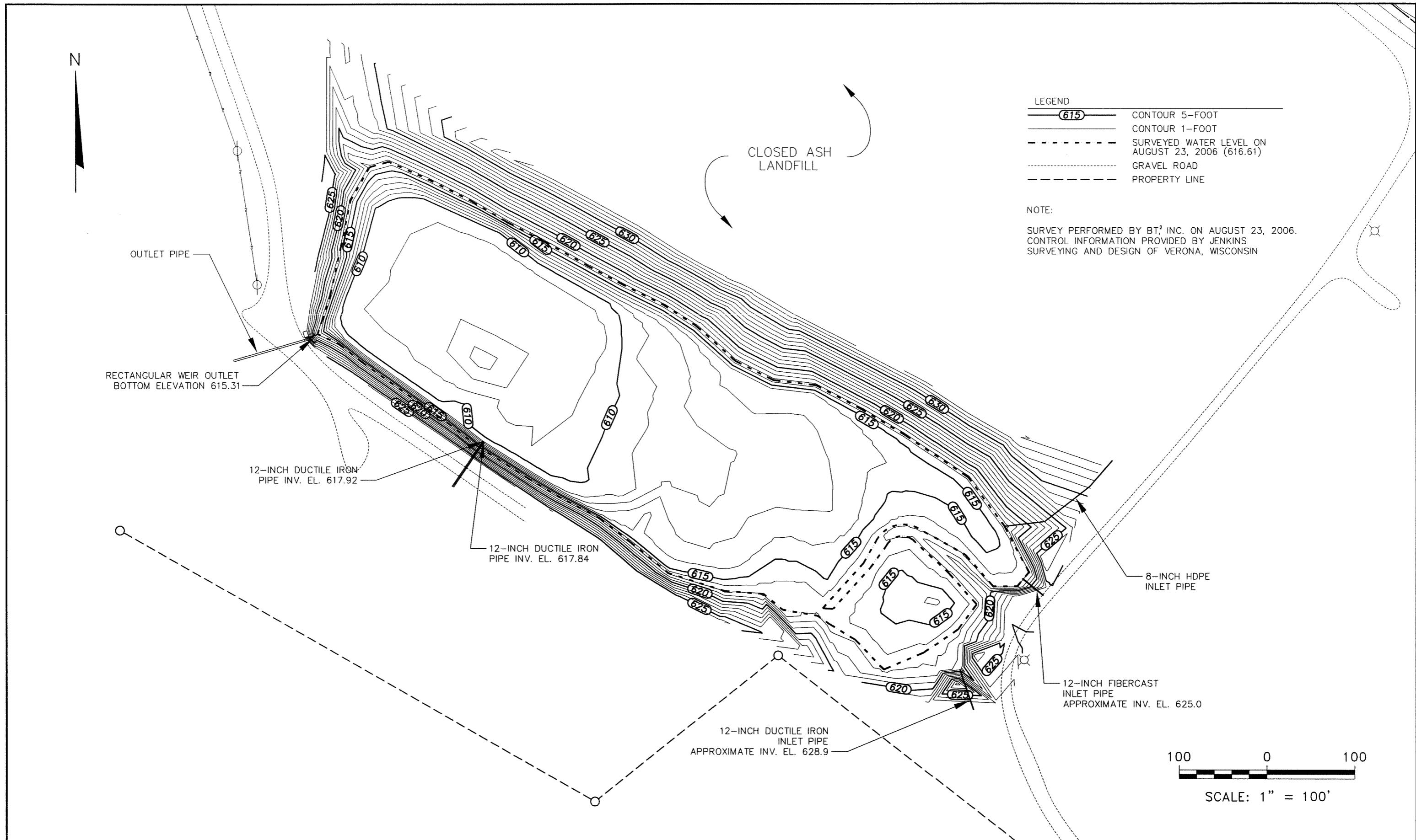

LEGEND

	CONTOUR 5-FOOT
	CONTOUR 1-FOOT
	SURVEYED WATER LEVEL ON AUGUST 23, 2006 (616.61)
	GRAVEL ROAD
	PROPERTY LINE

NOTE:
 SURVEY PERFORMED BY BT² INC. ON AUGUST 23, 2006.
 CONTROL INFORMATION PROVIDED BY JENKINS SURVEYING AND DESIGN OF VERONA, WISCONSIN

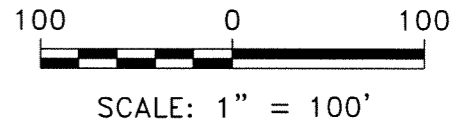

PROJECT NO. 3197	DRAWN BY: TR		2830 DAIRY DRIVE MADISON, WI 53718-6751 PHONE: (608) 224-2830 FAX: (608) 224-2839		ALLIANT ENERGY NELSON DEWEY ENERGY CENTER 11999 CTH VV CASSVILLE, WISCONSIN	ALLIANT NELSON DEWEY 11999 CTH VV CASSVILLE, WISCONSIN	SLAG POND TOPOGRAPHIC SURVEY	SHEET
DRAWN: 08/29/06	CHECKED BY: SC							
REVISED: 09/05/06	APPROVED BY:							2 OF 22

APPENDIX D – Inflow Flood Control Analysis

Alliant Energy
Wisconsin Power and Light Company
Nelson Dewey Generating Station
Cassville, Wisconsin

Inflow Design Flood Control System Plan



Hydrograph Plot

Hydraflow Hydrographs by Intelisolve

Hyd. No. 2

Slag Pond Outflow

Hydrograph type = Reservoir
Storm frequency = 100 yrs
Inflow hyd. No. = 1
Max. Elevation = 617.13 ft

Peak discharge = 22.20 cfs
Time interval = 2 min
Reservoir name = Slag Pond
Max. Storage = 7.940 acft

Storage Indication method used.

Hydrograph Volume = 13.564 acft

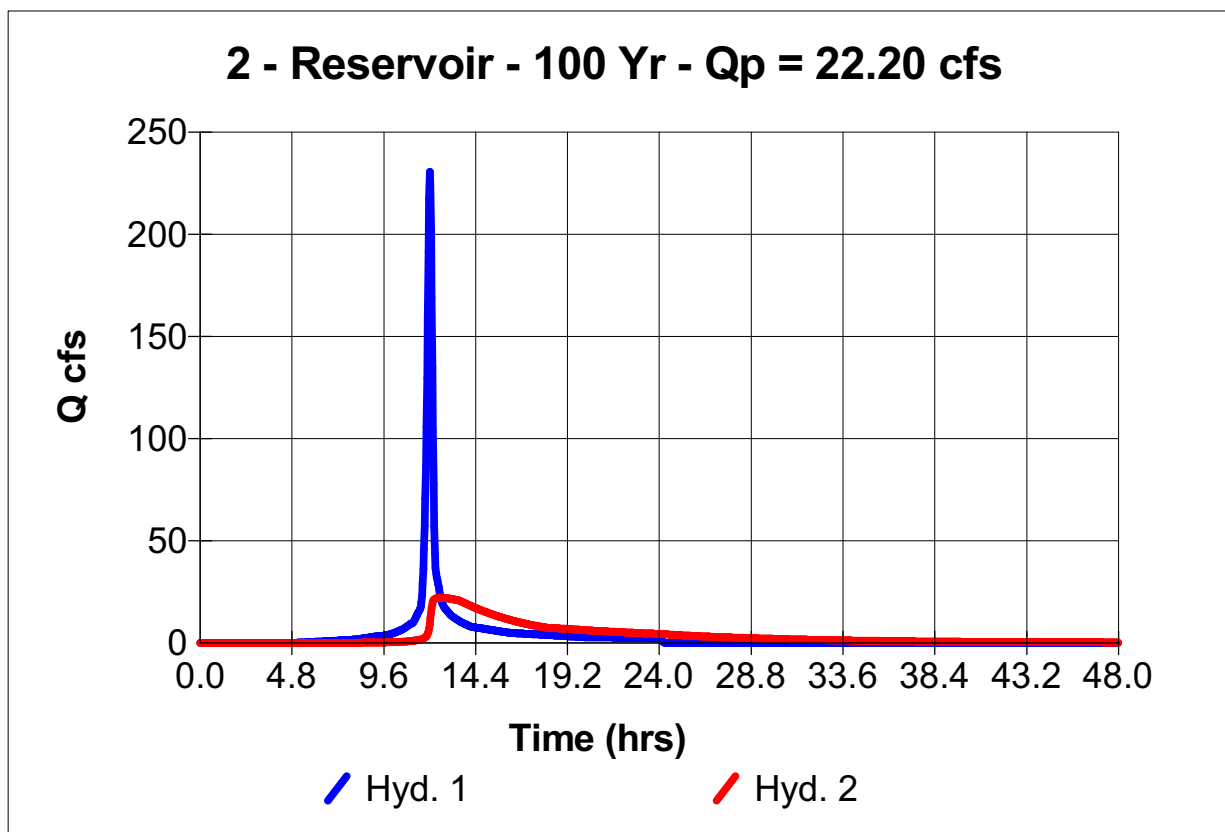

Hydrograph Summary Report

Hyd. No.	Hydrograph type (origin)	Peak flow (cfs)	Time interval (min)	Time to peak (min)	Volume (acft)	Inflow hyd(s)	Maximum elevation (ft)	Maximum storage (acft)	Hydrograph description
1	SCS Runoff	230.63	2	720	14.109	---	-----	-----	Capped Ash Landfill
2	Reservoir	22.20	2	754	13.564	1	617.13	7.940	Slag Pond Outflow

Proj. file: Cassville Slag.gpw	Return Period: 100 yr	Run date: 08-11-2016
--------------------------------	-----------------------	----------------------

Hydrograph Report

Hyd. No. 1

Capped Ash Landfill

Hydrograph type	= SCS Runoff	Peak discharge	= 230.63 cfs
Storm frequency	= 100 yrs	Time interval	= 2 min
Drainage area	= 30.00 ac	Curve number	= 83
Basin Slope	= 4.0 %	Hydraulic length	= 690 ft
Tc method	= LAG	Time of conc. (Tc)	= 10.7 min
Total precip.	= 7.47 in	Distribution	= Type II
Storm duration	= 24 hrs	Shape factor	= 484

Hydrograph Volume = 14.109 acft

Hydrograph Discharge Table

Time -- Outflow (hrs cfs)	Time -- Outflow (hrs cfs)	Time -- Outflow (hrs cfs)
8.57 2.34	15.37 6.21	22.17 2.65
8.77 2.65	15.57 5.91	22.37 2.63
8.97 2.97	15.77 5.61	22.57 2.60
9.17 3.27	15.97 5.30	22.77 2.58
9.37 3.43	16.17 5.04	22.97 2.56
9.57 3.57	16.37 4.91	23.17 2.54
9.77 3.92	16.57 4.80	23.37 2.52
9.97 4.44	16.77 4.70	23.57 2.50
10.17 5.04	16.97 4.59	23.77 2.48
10.37 5.82	17.17 4.48	23.97 2.45
10.57 6.68	17.37 4.37	
10.77 7.84	17.57 4.27	
10.97 9.27	17.77 4.16	...End
11.17 10.44	17.97 4.05	
11.37 14.32	18.17 3.94	
11.57 19.88	18.37 3.83	
11.77 70.66	18.57 3.73	
11.97 217.64	18.77 3.62	
12.17 104.10	18.97 3.51	
12.37 32.18	19.17 3.40	
12.57 22.76	19.37 3.29	
12.77 17.41	19.57 3.18	
12.97 15.15	19.77 3.07	
13.17 13.15	19.97 2.96	
13.37 11.85	20.17 2.87	
13.57 10.66	20.37 2.84	
13.77 9.67	20.57 2.82	
13.97 8.81	20.77 2.80	
14.17 8.06	20.97 2.78	
14.37 7.70	21.17 2.75	
14.57 7.41	21.37 2.73	
14.77 7.11	21.57 2.71	
14.97 6.81	21.77 2.69	
15.17 6.51	21.97 2.67	

Hydrograph Report

Hyd. No. 2

Slag Pond Outflow

Hydrograph type = Reservoir
 Storm frequency = 100 yrs
 Inflow hyd. No. = 1
 Max. Elevation = 617.13 ft

Peak discharge = 22.20 cfs
 Time interval = 2 min
 Reservoir name = Slag Pond
 Max. Storage = 7.940 acft

Storage Indication method used.

Outflow hydrograph volume = 13.564 acft

Hydrograph Discharge Table

Time (hrs)	Inflow cfs	Elevation ft	Clv A cfs	Clv B cfs	Clv C cfs	Clv D cfs	Wr A cfs	Wr B cfs	Wr C cfs	Wr D cfs	Exfil cfs	Outflow cfs
11.80	86.40	615.88	----	----	----	----	----	----	----	----	----	3.09
12.00	230.63 <<	616.47	----	----	----	----	----	----	----	----	----	9.08
12.20	77.70	617.03	----	----	----	----	----	----	----	----	----	21.14
12.40	30.60	617.11	----	----	----	----	----	----	----	----	----	22.04
12.60	21.41	617.13	----	----	----	----	----	----	----	----	----	22.20
12.80	16.99	617.11	----	----	----	----	----	----	----	----	----	22.06
13.00	14.78	617.09	----	----	----	----	----	----	----	----	----	21.80
13.20	12.90	617.06	----	----	----	----	----	----	----	----	----	21.47
13.40	11.65	617.03	----	----	----	----	----	----	----	----	----	21.08
13.60	10.48	616.99	----	----	----	----	----	----	----	----	----	20.53
13.80	9.52	616.95	----	----	----	----	----	----	----	----	----	19.69
14.00	8.66	616.91	----	----	----	----	----	----	----	----	----	18.84
14.20	7.98	616.87	----	----	----	----	----	----	----	----	----	17.99
14.40	7.65	616.84	----	----	----	----	----	----	----	----	----	17.17
14.60	7.36	616.80	----	----	----	----	----	----	----	----	----	16.40
14.80	7.06	616.77	----	----	----	----	----	----	----	----	----	15.66
15.00	6.76	616.73	----	----	----	----	----	----	----	----	----	14.96
15.20	6.46	616.70	----	----	----	----	----	----	----	----	----	14.29
15.40	6.16	616.68	----	----	----	----	----	----	----	----	----	13.65
15.60	5.86	616.65	----	----	----	----	----	----	----	----	----	13.04
15.80	5.56	616.62	----	----	----	----	----	----	----	----	----	12.45
16.00	5.25	616.59	----	----	----	----	----	----	----	----	----	11.88
16.20	5.01	616.57	----	----	----	----	----	----	----	----	----	11.34
16.40	4.89	616.55	----	----	----	----	----	----	----	----	----	10.83
16.60	4.79	616.52	----	----	----	----	----	----	----	----	----	10.35
16.80	4.68	616.50	----	----	----	----	----	----	----	----	----	9.90
17.00	4.57	616.49	----	----	----	----	----	----	----	----	----	9.47
17.20	4.46	616.47	----	----	----	----	----	----	----	----	----	9.08
17.40	4.36	616.45	----	----	----	----	----	----	----	----	----	8.70
17.60	4.25	616.43	----	----	----	----	----	----	----	----	----	8.35
17.80	4.14	616.42	----	----	----	----	----	----	----	----	----	8.02
18.00	4.03	616.40	----	----	----	----	----	----	----	----	----	7.70
18.20	3.92	616.39	----	----	----	----	----	----	----	----	----	7.52
18.40	3.82	616.38	----	----	----	----	----	----	----	----	----	7.39
18.60	3.71	616.36	----	----	----	----	----	----	----	----	----	7.26
18.80	3.60	616.35	----	----	----	----	----	----	----	----	----	7.14
19.00	3.49	616.34	----	----	----	----	----	----	----	----	----	7.02
19.20	3.38	616.32	----	----	----	----	----	----	----	----	----	6.89

Continues on next page...

Hydrograph Discharge Table

Time (hrs)	Inflow cfs	Elevation ft	Clv A cfs	Clv B cfs	Clv C cfs	Clv D cfs	Wr A cfs	Wr B cfs	Wr C cfs	Wr D cfs	Exfil cfs	Outflow cfs
19.40	3.27	616.31	----	----	----	----	----	----	----	----	----	6.77
19.60	3.16	616.30	----	----	----	----	----	----	----	----	----	6.65
19.80	3.05	616.28	----	----	----	----	----	----	----	----	----	6.52
20.00	2.95	616.27	----	----	----	----	----	----	----	----	----	6.40
20.20	2.86	616.26	----	----	----	----	----	----	----	----	----	6.28
20.40	2.84	616.24	----	----	----	----	----	----	----	----	----	6.16
20.60	2.82	616.23	----	----	----	----	----	----	----	----	----	6.05
20.80	2.79	616.22	----	----	----	----	----	----	----	----	----	5.94
21.00	2.77	616.21	----	----	----	----	----	----	----	----	----	5.83
21.20	2.75	616.20	----	----	----	----	----	----	----	----	----	5.72
21.40	2.73	616.19	----	----	----	----	----	----	----	----	----	5.62
21.60	2.71	616.17	----	----	----	----	----	----	----	----	----	5.52
21.80	2.69	616.16	----	----	----	----	----	----	----	----	----	5.42
22.00	2.67	616.15	----	----	----	----	----	----	----	----	----	5.33
22.20	2.64	616.14	----	----	----	----	----	----	----	----	----	5.23
22.40	2.62	616.13	----	----	----	----	----	----	----	----	----	5.14
22.60	2.60	616.12	----	----	----	----	----	----	----	----	----	5.06
22.80	2.58	616.12	----	----	----	----	----	----	----	----	----	4.97
23.00	2.56	616.11	----	----	----	----	----	----	----	----	----	4.89
23.20	2.54	616.10	----	----	----	----	----	----	----	----	----	4.81
23.40	2.51	616.09	----	----	----	----	----	----	----	----	----	4.73
23.60	2.49	616.08	----	----	----	----	----	----	----	----	----	4.65
23.80	2.47	616.07	----	----	----	----	----	----	----	----	----	4.58
24.00	2.45	616.07	----	----	----	----	----	----	----	----	----	4.50
24.20	0.63	616.05	----	----	----	----	----	----	----	----	----	4.41
24.40	0.00	616.04	----	----	----	----	----	----	----	----	----	4.26
24.60	0.00	616.02	----	----	----	----	----	----	----	----	----	4.11
24.80	0.00	616.01	----	----	----	----	----	----	----	----	----	3.97
25.00	0.00	615.99	----	----	----	----	----	----	----	----	----	3.85
25.20	0.00	615.98	----	----	----	----	----	----	----	----	----	3.76
25.40	0.00	615.96	----	----	----	----	----	----	----	----	----	3.66
25.60	0.00	615.95	----	----	----	----	----	----	----	----	----	3.57
25.80	0.00	615.94	----	----	----	----	----	----	----	----	----	3.48
26.00	0.00	615.92	----	----	----	----	----	----	----	----	----	3.40
26.20	0.00	615.91	----	----	----	----	----	----	----	----	----	3.31
26.40	0.00	615.90	----	----	----	----	----	----	----	----	----	3.23
26.60	0.00	615.89	----	----	----	----	----	----	----	----	----	3.15
26.80	0.00	615.87	----	----	----	----	----	----	----	----	----	3.07
27.00	0.00	615.86	----	----	----	----	----	----	----	----	----	3.00
27.20	0.00	615.85	----	----	----	----	----	----	----	----	----	2.92
27.40	0.00	615.84	----	----	----	----	----	----	----	----	----	2.85
27.60	0.00	615.83	----	----	----	----	----	----	----	----	----	2.78
27.80	0.00	615.82	----	----	----	----	----	----	----	----	----	2.71
28.00	0.00	615.81	----	----	----	----	----	----	----	----	----	2.64
28.20	0.00	615.80	----	----	----	----	----	----	----	----	----	2.58
28.40	0.00	615.79	----	----	----	----	----	----	----	----	----	2.51
28.60	0.00	615.78	----	----	----	----	----	----	----	----	----	2.45
28.80	0.00	615.77	----	----	----	----	----	----	----	----	----	2.39
29.00	0.00	615.76	----	----	----	----	----	----	----	----	----	2.33
29.20	0.00	615.75	----	----	----	----	----	----	----	----	----	2.27

...End

